

## OVERALL CHARACTERISTICS

208Y/120 VAC or 480Y/277 VAC, 3 phase, 4 wire plus ground, input and output standard, optional voltages available

87% efficiency minimum

Operating temperature range 18°F (-8°C) to 104°F (40°C)\*

Internal maintenance by-pass is standard

Main input breaker standard

Main load disconnect breaker standard

Double conversion, no interruption

Standard backup time of 90 minutes

Output circuit breakers optional

Normally-off loads optional (non-HID applications only)

Some modules are field upgradeable

## APPLICATION

Operates incandescent, magnetic and electronic ballast fluorescent, high power factor compact fluorescent, and high intensity discharge (HID) lamp types

Consult factory for compatibility and performance with non-lighting loads and normally off, quartz lighting loads

## HOUSING

Free standing, NEMA 1 enclosure

Dead front panel

Acid resistant powder coat finish

Bottom access for conduit entries

Refer to chart on back for dimensions

## BATTERY

Maintenance free, sealed lead calcium battery with an expected life up to 10 years, and optimum operating range of 65°F (19°C) to 85°F (30°C)\*

\* Increases or decreases in temperature will affect battery performance. Optimum battery performance realized at 77°F (25°C). Batteries are rated at 100% capacity at 77°F (25°C).

# CEPEM

## 30,000 VA, Three Phase Uninterruptible Power Supplies (UPS) for Emergency Lighting Applications

### ELECTRONICS

Inverter

Transient response  $\leq 5\%$ ; Recovery time, 20 mS (100% load step)

3:1 crest factor capability

Completely solid-state IGBT PWM inverter

Inverter output distortion  $\leq 5\%$  THD (100% non-linear)

Inverter output distortion  $\leq 3\%$  THD (linear loads)

Output voltage regulation  $\pm 1\%$  of nominal at full load

Frequency: 60 Hz

Inverter efficiency  $\geq 90\%$

Load power factor capability is 0.5 lagging to 0.9 leading

K30 rated output power transformer

Automatic low battery voltage disconnect (LVD)

Rectifier

Input voltage range  $\pm 15\%$  of nominal

Full load walk-in from 25% to 100% of rated load in 10 seconds

Voltage regulation  $\pm 1\%$  maximum for input voltage and DC variations

Ripple voltage  $< 2\%$  rms voltage with inverter fully loaded and battery disconnected

SCR controlled

Rectifier efficiency  $\geq 97.7\%$

Static Transfer Switch

Overload rating 150% for 1 minute

Transfer time from inverter to utility  $< 0.5$  mS



Listed to  
UL 924



SHOWN: CEPEM302X2

### METERING/CONTROLS

A multilingual, alphanumeric display of two lines and 40 characters provides the following information:

- Inverter voltage/frequency/current
- DC volts/current
- Reserve voltage/frequency/current
- Battery volts/current
- Load voltage/frequency/current
- Load percentage/crest factor

Computer interface using volt-free relay contacts configured for IBM AS/400, DEC, DG, PRIME, HP and similar computers

Two RS232 ports for direct two-way communication between the computer and UPS including the UPS Monitoring and Shutdown option

Relay contacts to drive an optional remote alarm monitor

Self-diagnostics/battery discharge test with user selectable battery test intervals

## ORDERING INFORMATION



SERIES

CEPEM = Three  
Phase UPS System



VA  
RATING

30 = 30,000

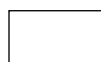

INPUT/OUTPUT

2X2 = 208Y/120 Input, 208Y/120 Output  
4X2 = 480 Input, 208Y/120 Output  
4X4 = 480Y/277 Input, 480Y/277 Output



OPTIONS

F = 10% Harmonic Distortion Filter  
OCB ( ) = Output Circuit Breakers (qty)  
NOL = Normally Off Load\*  
RAU = Remote Alarm Unit  
MSP = MopUPS Pro Monitoring Software Package  
FSU = Factory Start-up

SAMPLE CATALOG NUMBER: CEPEM302X2

\* Consult factory for quartz lamp normally off loads

## SYSTEM INPUT/OUTPUT

SYSTEM RATING	INPUT VOLTAGE	INPUT AMPS <sup>1</sup>	OUTPUT MAX. LOAD AMPS PER PHASE		MAXIMUM HEAT REJECTION
			120 V	277 V	
30,000 VA	208Y/120	99.7	83 A	—	11,300 Btu/hr 11,300 Btu/hr
	480Y/277	43.2	—	36 A	

NOTE: 1) Continuous Duty

## DIMENSIONS/WEIGHTS

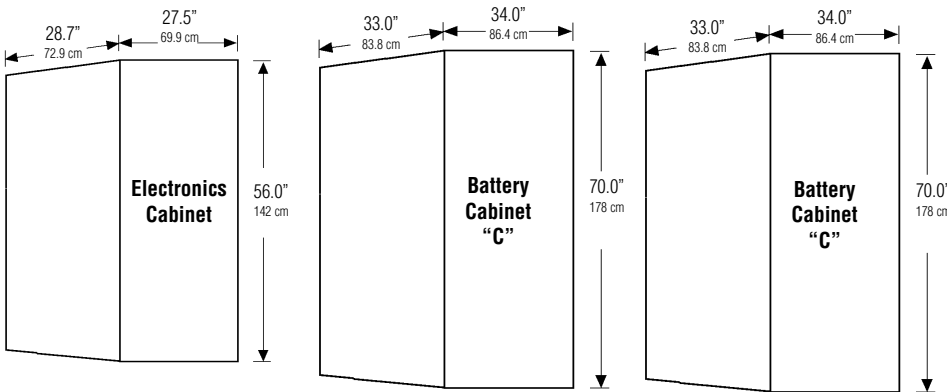

Unit	30 kVA
Electronics Cabinet	1,300 lbs. (590 kg)
Battery Cabinets*	1,100 lbs. (499 kg)
Battery	4,850 lbs. (2,200 kg)
Total System	7,250 lbs. (3,289 kg)

\* Total weight of two cabinets.

## SYSTEM ONE-LINE DIAGRAMS

30 kVA (2 x 2)

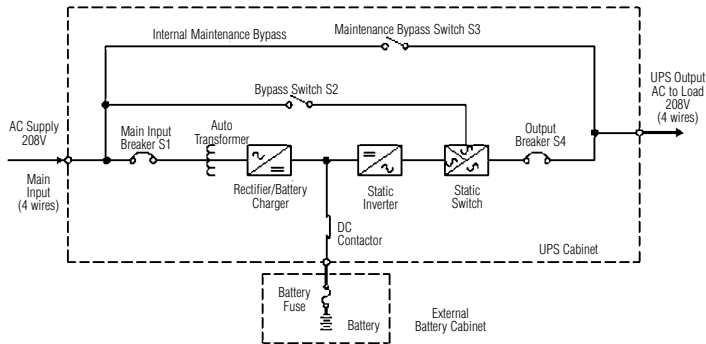

30 kVA (4 x 4)

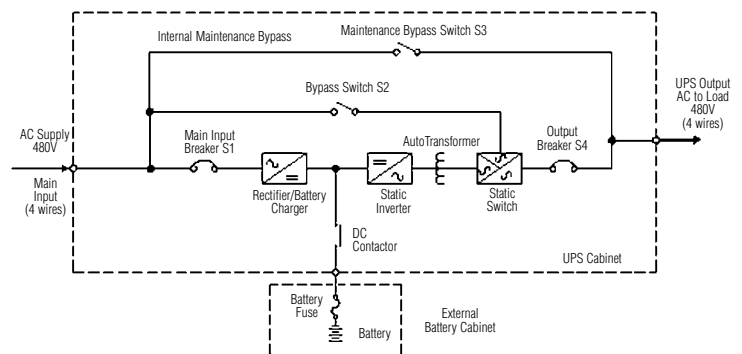

30 kVA (4 x 2)

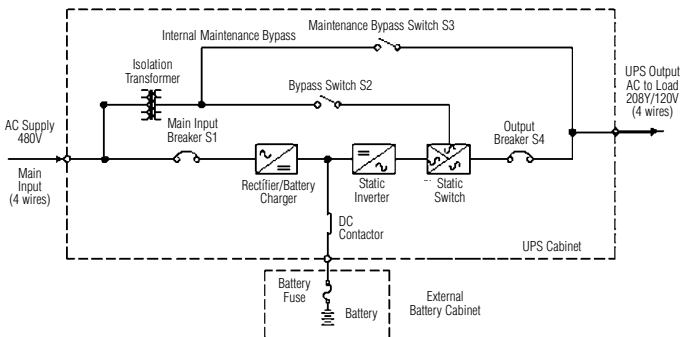

## WARRANTY

When Factory Start-up is performed in accordance with published requirements, warranty period extends one year from date of start-up. See Chloride Limited Warranty for details.

ALL SPECIFICATIONS SUBJECT TO CHANGE WITHOUT NOTICE



**CHLORIDE**  
SYSTEMS

272 West Stag Park Service Road • Burgaw NC 28425  
Telephone: (910) 259 1000 • Facsimile: (800) 258 8803  
www.chloridesys.com

## CEPEM UPS System for Emergency Lighting Applications, 30,000 VA

### SUGGESTED SPECIFICATION

Furnish and install Chloride's three phase UPS system known as CEPEM with a VA rating of 30,000 VA. The system shall be ETL listed to Underwriters' Laboratories standard 924.

Equipment and accessories furnished under the terms of this specification shall be the standard product of a single manufacturer and shall be equal in all respects to those supplied by Chloride. Catalog numbers and model designations which appear herein indicate design, quality and the type of material as well as required operating characteristics. All equipment shall be in compliance with the applicable UL standards.

The connected load shall be powered normally by the CEPEM rectifier and inverter and upon failure of the utility input, the load shall automatically continue to be powered via the CEPEM system's battery and inverter for a minimum of 1.5 hours. Upon restoration of utility power, the rectifier will automatically walk-in the inverter and recharge the batteries even if the batteries are completely discharged.

The CEPEM System shall be capable of powering any combination of fluorescent ballasted lamps, incandescent lamps, electronic and high power factor compact fluorescent ballasts, HID lamps or other approved loads up to the total rating of the system. The system shall automatically protect itself against damage from overloads and short circuits.

Under emergency operations, the output voltage shall be within  $\pm 1\%$  of nominal at full load for the specified discharge period; and the frequency shall be 60 Hz  $\pm 0.05\%$ .

During emergency operation, the systems' efficiency shall not be less than 90%. The system shall use fans in the electronic compartments for forced air ventilation. The AC output to the load shall be isolated from the utility input during emergency operation.

The Chloride rectifier shall be SCR controlled. The rectifier efficiency shall not be less than 97.7%. The rectifier shall have a ripple voltage less than 2% rms voltage with inverter fully loaded and battery disconnected. Charge voltage applied to the batteries shall be temperature compensated.

The static transfer switch shall have an overload rating of 150% for 1 minute. Transfer time from inverter to utility shall be less than 0.5 milliseconds.

Under emergency mode conditions, the CEPEM shall be powered by sealed, recombination lead calcium batteries. The battery shall operate entirely unattended and require no addition of water for a period of 10 years or longer. Periodic inspection of batteries is recommended.

A low voltage disconnect circuit designed to reduce battery discharge during extended power outages, shall monitor the battery voltage and disconnect the inverter when battery voltage drops to approximately 85% of nominal voltage.

System metering and controls shall consist of computer interface, RS232 port for direct two-way communication, relay contacts to drive an optional remote alarm monitor, a multilingual alphanumeric display of voltage/frequency/current, load percentage, crest factor and options as noted.

### UNIT CHECK LIST

<b>Catalog No.</b> _____	<b>VA Rating:</b> 30,000
<b>Battery Type:</b> PRC	<b>Operating Time:</b> 90 Min.
<b>Input:</b> _____ VAC; Three Phase	<b># of Wires:</b> _____ plus Ground
<b>Output:</b> _____ VAC; Three Phase	<b># of Wires:</b> _____ plus Ground
<b>Options:</b> F      OCB(#)	NOL      RAU      MSP      FSU
<b>REMARKS:</b> _____	
_____	

ALL SPECIFICATIONS SUBJECT TO CHANGE WITHOUT NOTICE

