

GENERAL DESCRIPTION

The Rhyno Series is a state of the art industrial emergency lighting product for extreme environments. The Rhyno Series is designed to be protected against liquid, moisture, dirt, and dust entry. The Rhyno Series is approved for NEMA 4X and IP66 areas, and is additionally UL listed for wet locations, cold ambient conditions, high ambient conditions, and extreme ambient conditions.

ILLUMINATION

Illumination is accomplished with up to three lamp heads internally mounted on the bottom of the unit for optimum path of egress illumination. Lamps are held in a molded swivel assembly and are fully adjustable. Each lamp head utilizes a PAR 36 sealed beam tungsten or halogen lamp.

INSTALLATION

The Rhyno Series is supplied standard with a wall mount bracket. A universal mounting kit for column, pole, or I-beam mounting is available as an accessory item.

DIMENSIONS

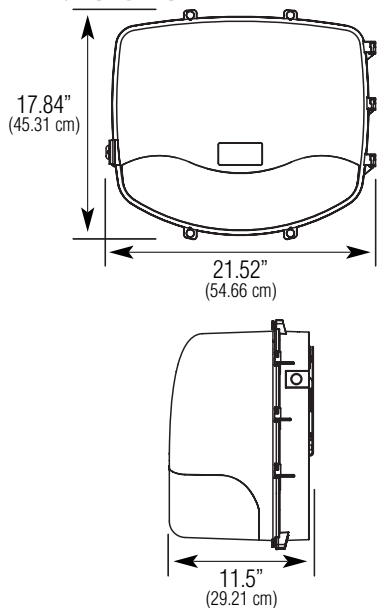

See reverse for more dimensions.

Rhyno Series

NEMA 4X, IP66, Harsh Environment Emergency Lighting Standard Self-Diagnostics Electronics* 12 and 24 Volt, 200 to 450 Watts**

*Self-powered models incorporate the Intelli-Charge diagnostics electronics package. Self-testing is a factory installed option.
**24 volt system available in 300 and 450 watt capacity only

HOUSING

Constructed of impact-resistant Lexan® with corrosion resistant hardware. Housing color is gray. A one-piece, molded gasket, and unexposed metallic hardware prolong product life in highly corrosive areas. A hinged, removable cover allows for hands-free wiring. Housing is rated for use in NEMA 4X and IP66 areas and is additionally UL wet location listed.

ELECTRONICS

120/277 VAC dual voltage input with surge protection is standard on all models. Charging system is microprocessor driven with software embedded diagnostic routine and precision temperature compensation. See specification sheet C1059 for technical specifications for the electronics. Surge protection, brownout, AC lockout, and low voltage disconnect features are standard.

BATTERY

The Rhyno battery assemblies have been pre-qualified for use based on anticipated ambient temperatures. Battery chemistries consist of sealed maintenance-free lead calcium and pure lead. Batteries supply a minimum of 90 minutes of emergency power at the lowest rated temperature of the model selected without de-rating the fixture.

INTELLI-CHARGE SELF-TESTING DIAGNOSTICS (OPTIONAL)

The Intelli-Charge diagnostic/charging platform with self-testing mode automatically runs a one-minute self-test every 30 days and a 30-minute test on the sixth and twelfth month. A one-minute or 90-minute test may be initiated via the push to test switch on the unit or by activating the appropriate test command on the optional IR test device.

WARRANTY

Three year full electronics warranty.
One year full plus four year prorated lead calcium or pure lead battery warranty.



SHOWN: RN230PF3IC

ELECTRICAL SPECIFICATIONS

Input Power Requirements

12 Volt, Standard

120 VAC, 60 Hz = 0.560A, 277 VAC, 60 Hz = 0.236A

12 Volt, 'C' - Cold Ambient

120 VAC, 60 Hz = 0.984A, 277 VAC, 60 Hz = 0.422A

12 Volt, 'H' - High Ambient Units

120 VAC, 60 Hz = 0.463A, 277 VAC, 60 Hz = 0.192A

12 Volt, 'E' - Extreme Ambient Units

120 VAC, 60 Hz = 0.992A, 277 VAC, 60 Hz = 0.443A

24 Volt, Standard

120 VAC, 60 Hz = 0.697A, 277 VAC, 60 Hz = 0.304A

24 Volt, 'C' - Cold Ambient

120 VAC, 60 Hz = 1.343A, 277 VAC, 60 Hz = 0.594A

24 Volt, 'H' - High Ambient Units

120 VAC, 60 Hz = 0.741A, 277 VAC, 60 Hz = 0.312A

24 Volt, 'E' - Extreme Ambient Units

120 VAC, 60 Hz = 1.256A, 277 VAC, 60 Hz = 0.548A

CODE COMPLIANCE

UL 924 listed
UL wet location listed
NSF Standard 2 "Splash Zone"
NEMA 250 (NEMA 4X classification)
NFPA 101, NEC, IBC, BOCA, and OSHA illumination standard
IEC 529 (60529) IP66
Model numbers RN220PF2IC and RN230PF3IC (both available with factory installed options) are UL 924 listed for 8-hour run time in the emergency mode

ORDERING INFORMATION (EXAMPLE: RN230PF3IC)

RN							IC	
SERIES RN = Rhyno Series Industrial Emergency Lighting Fixture	BATTERY VOLTAGE 2 = 12 Volts DC 4 = 24 Volts DC ²	CAPACITY 20 = 200 Watts 25 = 250 Watts 30 = 300 Watts 40 = 400 Watts 45 = 450 Watts	ENVIRONMENT*** See Capacity & Environment for Limited Availability*** Blank = Wet Location Listed (0°C to 40°C) C = Cold Ambient Conditions, Wet Location Listed (-40°C to 40°C) H = High Ambient Conditions, Wet Location Listed (0°C to 55°C) E = Extreme Ambient Conditions, Wet Location Listed (-40°C to 55°C)	LAMP DESIGNATOR 12 Volt, PAR 36 Sealed Beam Tungsten PE = 12 Watt PF = 18 Watt PG = 25 Watt PH = 30 Watt 12 Volt, PAR 36 Sealed Beam Halogen PK = 8 Watt PL = 12 Watt PM = 37 Watt PN = 50 Watt	LAMP HEAD QUANTITY 0 = No Heads 2 = Two Heads 3 = Three Heads	MODEL DESIGNATOR IC = Intelli-Charge Self-Diagnostic Electronics	OPTIONS A = Ammeter ACF1 = 120 Volt AC Input Fuse ACF2 = 277 Volt AC Input Fuse ACP1 = 120 Volt AC Disconnect Switch ACP2 = 277 Volt AC Disconnect Switch BDS = Battery Disconnect Switch EX = Special Input Transformer ¹ (specify voltage & frequency) T = Self-Testing Diagnostics (non-audible) TA = Audible Self-Testing Diagnostics TD = Time Delay V = Voltmeter	
***CAPACITY & ENVIRONMENT SELECTION C = 12V, 300W; 24V, 300W H = 12V, 300W; 24V, 300W E = 12V, 300W; 24V, 300W All other configurations are standard wet location listed from 0°C to 40°C.								ACCESSORIES (order as a separate line item) NUMK = Universal Mounting Kit (column, pole, I-beam) ICIR = Intelli-Charge Infra-Red Remote
Notes: 1) Certain option combinations may impact UL listing, consult factory. 2) 24 volt systems only available in 300 and 450 watt configurations.								

Specification Data for Rhino Series

HOUSING

Constructed of impact-resistant Lexan®. Housing color is gray. Housing is rated for use in NEMA 4X and IP66 areas and is additionally UL wet location listed.

Includes one-piece, molded formed-in-place gasket and unexposed metallic hardware.

Hands-free wiring is possible with a hinged, removable cover.

ILLUMINATION

The Rhino Series is available with or without lamp heads installed on the fixture. Available lamp heads include Par 36 sealed beam tungsten or halogen lamps in a fully adjustable swivel assembly.

Full IES file data support is available on-line at www.chloridesys.com.

ELECTRONICS

Intelli-Charge Standard Features

All operational features of the Rhino Series are controlled by an 8-bit microprocessor to provide unmatched reliability and performance.

Microprocessor standard features include:

- Transformer isolated input
- Low-voltage disconnect (LVD)
- AC lockout (line latch)
- AC power indicator
- Brownout protection
- Charge status indicator
- Visual fault indicator
- Audible user interface control
- On-board IR receiver
- Precision temperature compensation

For detailed specifications regarding the Intelli-Charge for unit equipment, see specification sheet C1059.

Dual voltage 120/277 VAC, 60 Hz input with surge protection is standard on all models.

The low voltage disconnect (LVD) feature will disconnect the battery prior to an unacceptable deep discharge, but not before the required 90 minute emergency operation.

The brownout protection circuitry will automatically switch the unit into the emergency mode if the utility voltage drops below 25% of nominal input voltage.

The AC lockout (line latch) feature prevents battery drain prior to the initial energizing of utility power, and allows the installer to complete all wiring and electrical connections without energizing the emergency circuit.

BATTERY

Maintenance-free sealed lead calcium and pure lead batteries are pre-qualified based on anticipated ambient temperature exposure.

All capacity ratings are based on the lowest extreme temperature rating of the fixture, producing a minimum of 90 minutes emergency operation without de-rating the unit.

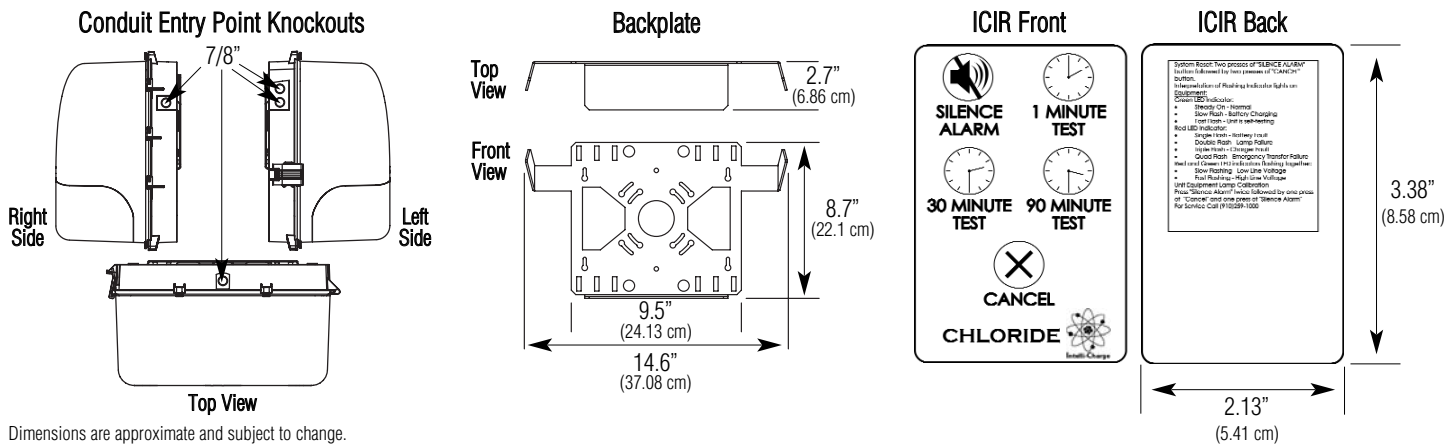

Dimensions are approximate and subject to change.

SUGGESTED SPECIFICATION

Furnish and install Chloride's Rhino Series emergency lighting unit model _____. The unit shall meet Underwriter's Laboratories, Inc. Standard #924 and the National Electrical Code (NEC). The unit shall be third party tested and approved for use in NEMA 4X areas in accordance with the requirements of NEMA 250, third party tested and approved for IP66 areas, third party tested and approved for NSF Standard 2 "Splash Zone", and be additionally UL wet location listed.

INSTALLATION AND OPERATION - Unit shall be easily field connected to a 120 or 277 VAC, 60 Hz, unswitched power source. Installation must comply with the NEC as well as other applicable codes. (Emergency Operation Only) - Upon utility power failure or brownout, the unit shall automatically transfer to battery power and maintain the required illumination level for a minimum period not less than 90 minutes at the coldest rated temperature of the unit. Upon restoration of utility power, the charger shall restore the battery to full charge within UL 924 requirements following a rated discharge of not less than 90 minutes.

ELECTRONICS - All models shall be provided with Chloride's Intelli-Charge self-diagnostics electronics platform. Intelli-Charge will detect and notify the installer regarding incorrect wiring of the transformer primary and restrict the damaging effects from affecting the printed circuit board. The Intelli-Charge electronics package shall provide continuous, real-time monitoring of all the critical equipment functions including, but not limited to: line voltage status and condition, charger fault, transfer fault, battery fault, and lamp load fault and notify personnel with a visual indicator sequence. Optional audible diagnostics shall be available from the factory. The optional self-testing software shall satisfy the periodic testing requirements in NFPA 101, Life Safety Code as well as the International Building Code (IBC). The Intelli-Charge diagnostic/charging platform with self-testing mode automatically runs a one-minute self-test every 30 days and a 30-minute test on the sixth and twelfth month. The Intelli-Charge circuit shall continuously sample ambient temperature conditions and adjust the charging regime to compensate for typical and dramatic ambient conditions equal to 3mv/°C compensation to maximize the life of the battery. An on-board IR receiver shall be standard and pre-programmed to operate from an optional IR user interface device (available as an accessory item).

BATTERY - The battery shall be either a maintenance-free sealed lead calcium or pure lead battery. The Rhino Series battery shall be pre-qualified based on anticipated ambient temperature conditions. The pure lead battery shall provide trouble-free operation in temperatures up to 131°F (55°C). The lead calcium battery shall provide trouble-free operation in temperatures up to 104°F (40°C). Lead calcium and pure lead batteries shall be supplied with a one year full warranty.

HOUSING - The unit housing shall be constructed of impact-resistant Lexan®. The housing color shall be gray.



272 West Stag Park Service Road • Burgaw NC 28425
 Telephone: (910) 259 1000 • Facsimile: (800) 258 8803
www.chloridesys.com

C1058R1
 5/09 IH