

DATE:

PROJECT

COMMENTS:



FEATURES

- Approved for use in the city of Chicago.
- Two, 6V adjustable white LED lamp heads in metal housing and PC lens provide optimal light distribution.
- 3.3W (3 LEDs x 1.1W) per head provides a light output of 335 lumens.
- Unique bi-color LED indicator light alerts occupant on battery condition (Green-normal, Red-check battery).
- Charge rate/power "ON" LED indicator light and push-to-test switch ensures mandated code compliance testing.
- LVD (low voltage disconnect) prevents battery from deep discharge.
- Internal solid-state transfer switch automatically connects the internal battery to the LED lamp heads for minimum 90-minute emergency illumination.
- Fully automatic solid-state, two rate charger initiates battery charging to recharge a discharged battery in 24 hours.



ORDERING INFORMATION *CEL-BK-MB*

1. SERIES

CEL

2. HOUSING

-

BK Black
WH White

3. MOUNTING

-

MB

MB Back Mount

ACCESSORIES; ORDER SEPARATELY

- **WG-16.5LX14.0WX3.0D** = Wireguard, Length: 16.5", Width: 14", Depth: 3"
- **WG-16.5LX14.0WX6.0D** = Wireguard, Length: 16.5", Width: 14", Depth: 6"
- **WG-20.0LX19.0WX9.0D** = Wireguard, Length: 20", Width: 19", Depth: 9"
- **WG-26.0LX19.0WX9.0D** = Wireguard, Length: 26", Width: 19", Depth: 9"

SPECIFICATIONS

CONSTRUCTION

- Durable, 20-gauge steel housing
- White or black powder coat finish

ELECTRICAL

- Dual 120/277 voltage
- 6V sealed lead acid, maintenance-free, rechargeable battery
- Remote capacity of 5.4W standard

MOUNTING

- Knockouts on the back for wall mount
- Side and top knockouts for conduit feed applications

TEMPERATURE RATING

- From 68°F to 122°F

APPROVALS

- City of Chicago Approved
- UL 924
- UL Listed for Damp Location
- NFPA Life Safety Code 101
- NFPA 70-NEC
- OSHA

WARRANTY

Isolite offers a 3-year limited warranty. For further details, refer to General Warranty and Obligations in the Isolite manual or on our website. Lamps not warranted.

DIMENSIONS

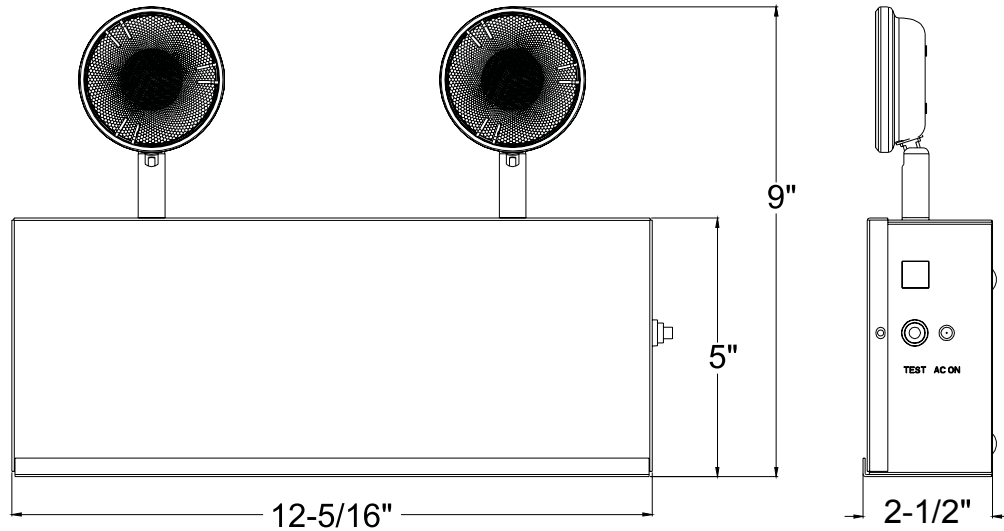

MAXIMUM SPACING GUIDELINES (IN FT)

MODEL #	MOUNTING HEIGHT (ft)	3 FT WIDE EGRESS PATH		6 FT WIDE EGRESS PATH		LUMEN PER LUMINAIRE	LUMINAIRE QUANTITY
		SINGLE FIXTURE (ft)	FIXTURE TO FIXTURE (ft)	SINGLE FIXTURE (ft)	FIXTURE TO FIXTURE (ft)		
CEL	7.5	58	62	52	55	336	2
	10	46	50	43	46		
	15	45	48	38	42		
	20	37	42	36	40		