



SPECIFICATION SHEET : WH44-UNV-L

This Is An Original Product From Fulham Co., Inc

**Description : WORKHORSE Electronic Ballast.
Parallel Lamp Operation.**

*** This Ballast Will Operate The Following Lamp Types:
CFQ, CFTR, CFT, FT, T9CR, T5CR, T5, T5HO, T6SL, T8, T8SL, T8HO, T10, T12, T12SL, T12HO
WHEN USED PER FULHAM'S LAMP/BALLAST WIRING DIAGRAM.**

ELECTRICAL DATA (Universal,120 - 277V)

INPUT VOLT: 120V - 277V ± 10%, 50/60Hz	
LAMP TYPE	CFQ, CFTR, CFT, FT, T9CR, T5CR, T5, T5HO, T6SL, T8, T8SL, T8HO, T10, T12, T12SL, T12HO
WIRING DIAGRAM #	REFER TO EACH LAMP TYPE / WATTAGE / No. OF LAMPS FOR WIRING DIAGRAM CHART
POWER FACTOR	HIGH POWER FACTOR
THD	< 10% @ FULL POWER
EMI/RFI COMPLIANCE	FCC PART 18-A
SOUND RATING	" A "
BALLAST TYPE	INSTANT START
VOLTAGE TRANSIENTS	ANSI C82.11 - 1993 / C62.41
MIN. OPERATING TEMP	0 °C (32 °F)
MAX. CASE TEMP	70 °C (158 °F)
APPROVALS/CLASS	UL LISTED, CLASS " P ", 1 OUTDOOR
* NOTE:	PLEASE CONTACT FULHAM CUSTOMER SERVICES FOR PERTICULAR LAMP SPECS.

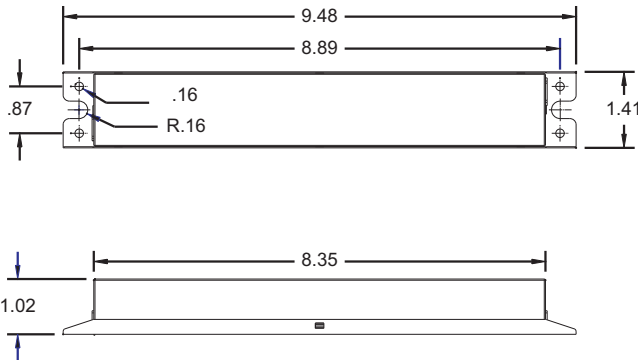
<p>IMAGE</p>  <p>NOTE : This ballast case must be grounded</p> <table border="1" style="width: 100%; border-collapse: collapse; margin-top: 10px;"> <tr> <th style="text-align: left;">WIRE</th> <th>BLACK</th> <th>WHITE</th> <th>RED</th> <th>BLUE</th> <th>YELLOW</th> <th>BROWN</th> </tr> <tr> <td>LENGTH - INCHES</td> <td>18 ± 1"</td> <td>18 ± 1"</td> <td>36 ± 1"</td> <td>-</td> <td>36 ± 1"</td> <td>-</td> </tr> </table>	WIRE	BLACK	WHITE	RED	BLUE	YELLOW	BROWN	LENGTH - INCHES	18 ± 1"	18 ± 1"	36 ± 1"	-	36 ± 1"	-	<p>MECHANICAL DATA</p>  <p style="text-align: center; margin-top: 10px;">Where : L = Length, W = Width, H = Height</p>
WIRE	BLACK	WHITE	RED	BLUE	YELLOW	BROWN									
LENGTH - INCHES	18 ± 1"	18 ± 1"	36 ± 1"	-	36 ± 1"	-									

Fulham extends a limited warranty only to the original purchaser or to the first user for a period of 5 years from the date of manufacture when properly installed and operated under normal conditions of use. For complete terms and conditions, please reference the Fulham product catalog (www.fulham.com)
Due to a program of continuous improvement, Fulham reserves the right to make modifications or variations in design or construction to the equipment described.